

Complete powder coating plants



Turnkey powder coating plants

AABO-IDEAL can offer turnkey customized finishing plants for powder coating.

These plants can for example include the following processes:

- Pretreatment such as manual washing down dirt and dust, grinding, sand-blasting, shotblasting, chemical pretreatment processes, conversion, e-coat.
- Heat treatment such as water drying, pre-heating of workpieces, curing of powder coating, technical heat finishing, high temperature finishing.
- Forced cooling zone.
- Manual and/or automatic spray/dip powder coating, powder teflon coating, powder epoxy coating.
- Manual, single and/or power and free conveyor systems.
- Fresh and wastewater treatment.



Energy efficient and environmentally friendly solutions

AABO-IDEAL offers the following solutions as part of our finishing plants:

- Integrated water saving system based on the counter-clockwise principle.
- Optimum insulation of tunnels, tanks and oven constructions.
- Bag and band filtering of chemical pretreatment processes.
- Optimized combustion and ventilation units.
- Mist eliminator or condensation unit in exhausting systems.

- Heat recovery between drying and curing oven sections.
- Optimized internal heat convection.
- Heat recovery systems.
- Combined drying and curing ovens.
- Oil skimmer and/or separator systems for integration in chemical degreasing tanks.
- Wastewater treatment plants.
- All motors comply with IEC standards and Eco design directive.
- Frequency control of motors.

AABO-IDEAL has more than six decades of experience in manufacturing industrial solutions for surface treatment, and over the years we have supplied many powder coating plants.

Each project has been thoroughly analyzed according to our customer's requirements and always ensuring a tailor-made, high performing and environmentally friendly operation.



**we
know
how**



Automatic plant example 1

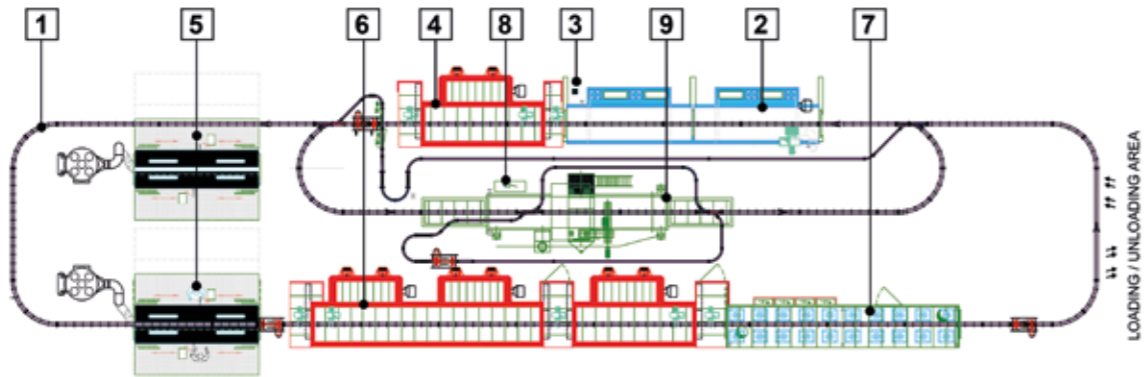

- 1 - Power & free conveyor
- 2 - Chamber pretreatment
- 3 - Fresh water purification: R.O. system
- 4 - Water drying oven
- 5 - 2 pcs. manual paint booths + application equipment
- 6 - Curing oven
- 7 - Forced cooling zone
- 8 - PC- PLC control unit
- 9 - Automatic shot blasting



TYPE:	Automatic
FINISHING:	Powder coating
CONVEYOR:	Power & free
SIZE (HxWxL):	1.500 x 700 x 4.000 mm
WEIGHT:	4.000 kg





Automatic plant example 2

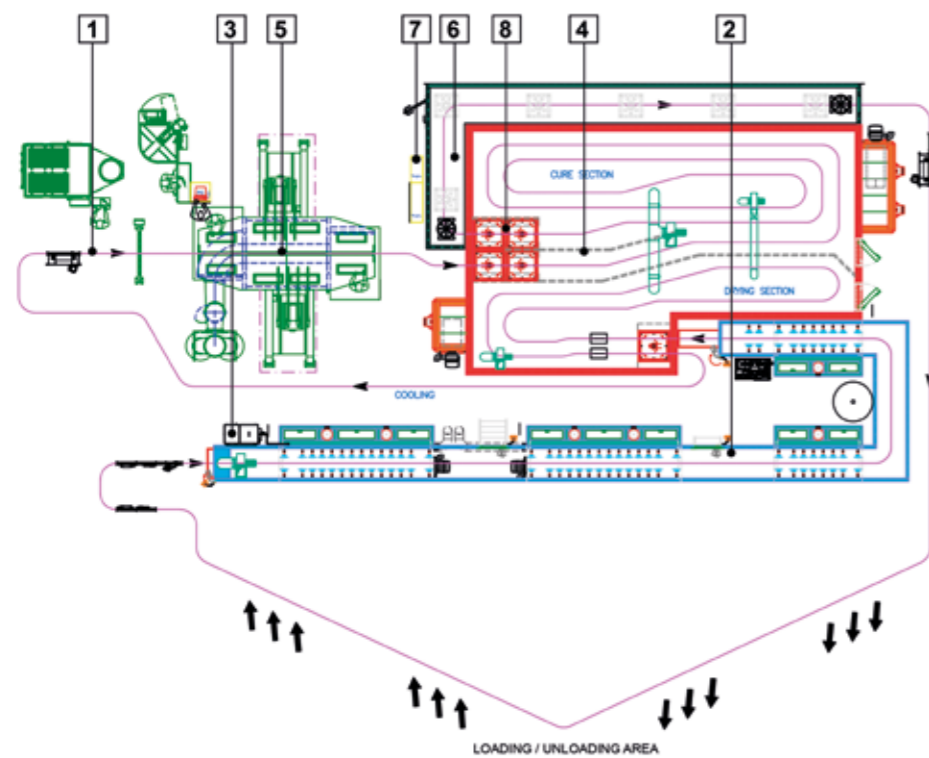

- 1 - Single conveyor w/lift system
- 2 - Tunnel spray pretreatment, 4 steps
- 3 - Fresh water purification: R.O. system
- 4 - Combined oven, water drying/curing
- 5 - Automatic powder coating
- 6 - Forced cooling zone
- 7 - PC-PLC control unit
- 8 - Heat recovery system

TYPE:	Automatic
FINISHING:	Powder coating
CONVEYOR:	Single
SIZE (HxWxL):	1.900 x 220 x 220 mm
WEIGHT:	25 kg





Manual plant example

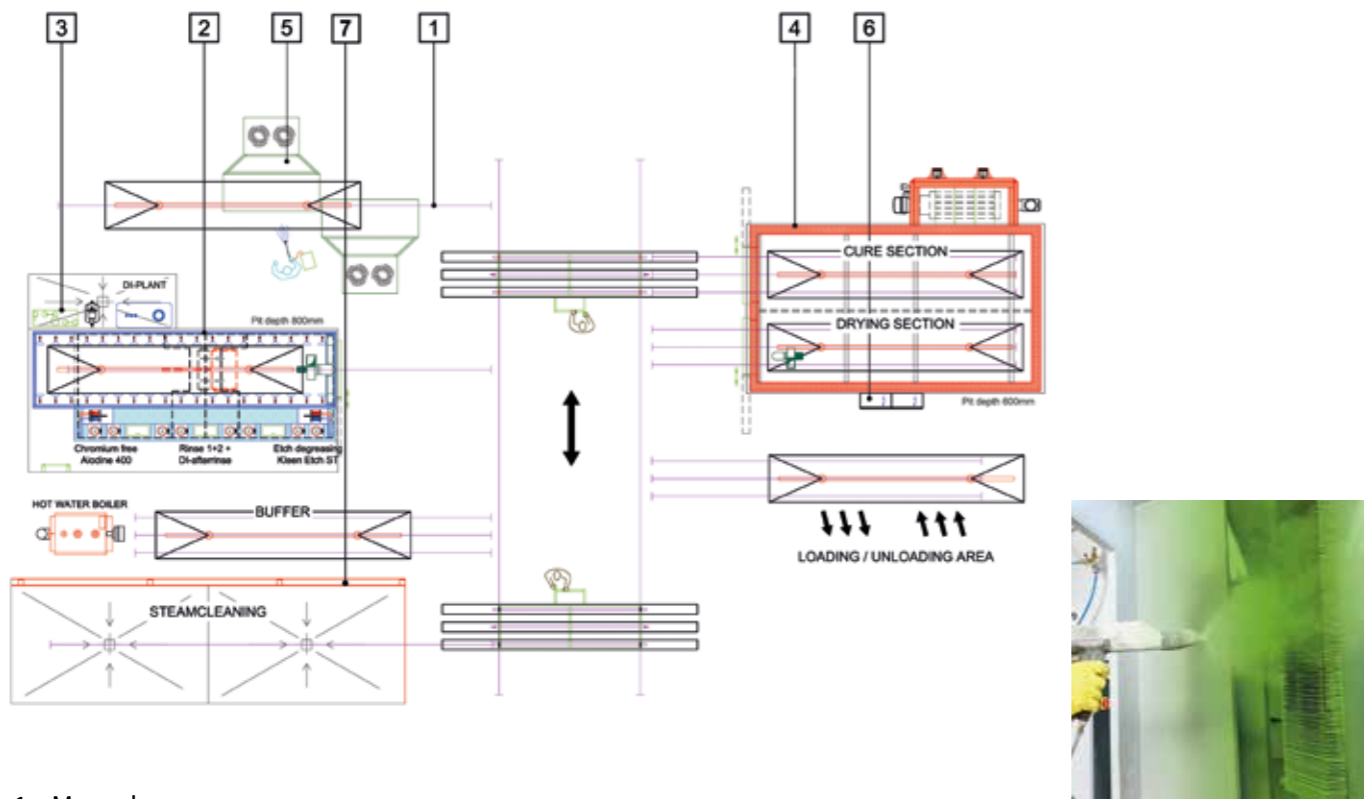

- 1 - Manual conveyor
- 2 - Chamber pretreatment, 6 steps
- 3 - Fresh water purification: R.O. system
- 4 - Combined box oven, water drying/curing
- 5 - Manual paint booth + application equipment
- 6 - PLC control unit
- 7 - Manual high-pressure cleaning

TYPE:	Manual
FINISHING:	Powder coating
CONVEYOR:	Manual
SIZE (HxWxL):	1.700 x 1.200 x 6.500 mm
WEIGHT:	200 kg





“Fluidized bed” dip plant example

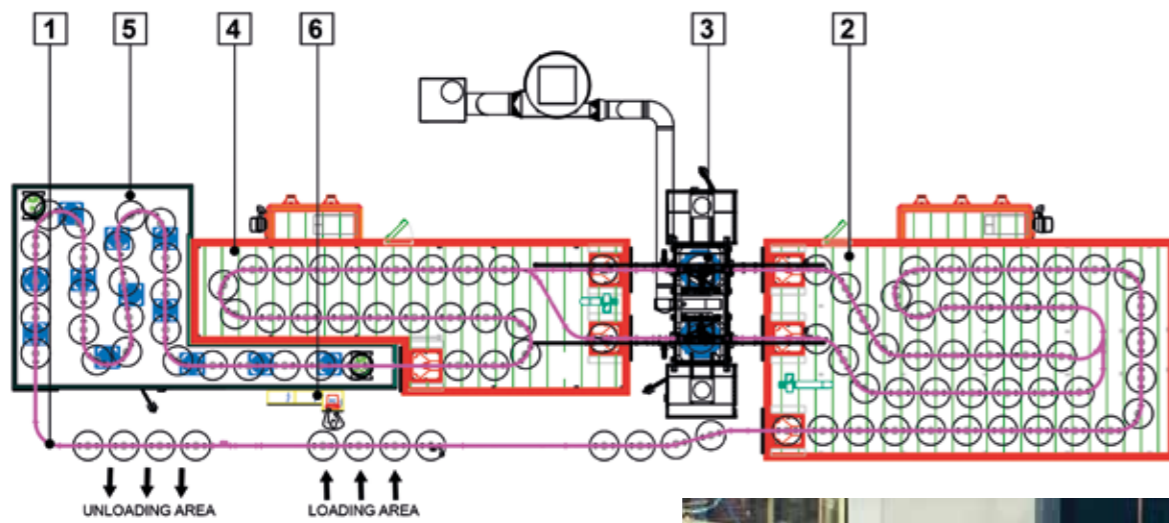

- 1 - Power & free conveyor
- 2 - Pre-heating oven
- 3 - “Fluidized bed” powder coating
- 4 - Curing oven
- 5 - Forced cooling zone
- 6 - PC-PLC control unit

TYPE:	Automatic
FINISHING:	Powder coating
CONVEYOR:	Power & free
SIZE (HxWxL):	500 x 850 x 850 mm
WEIGHT:	250 kg

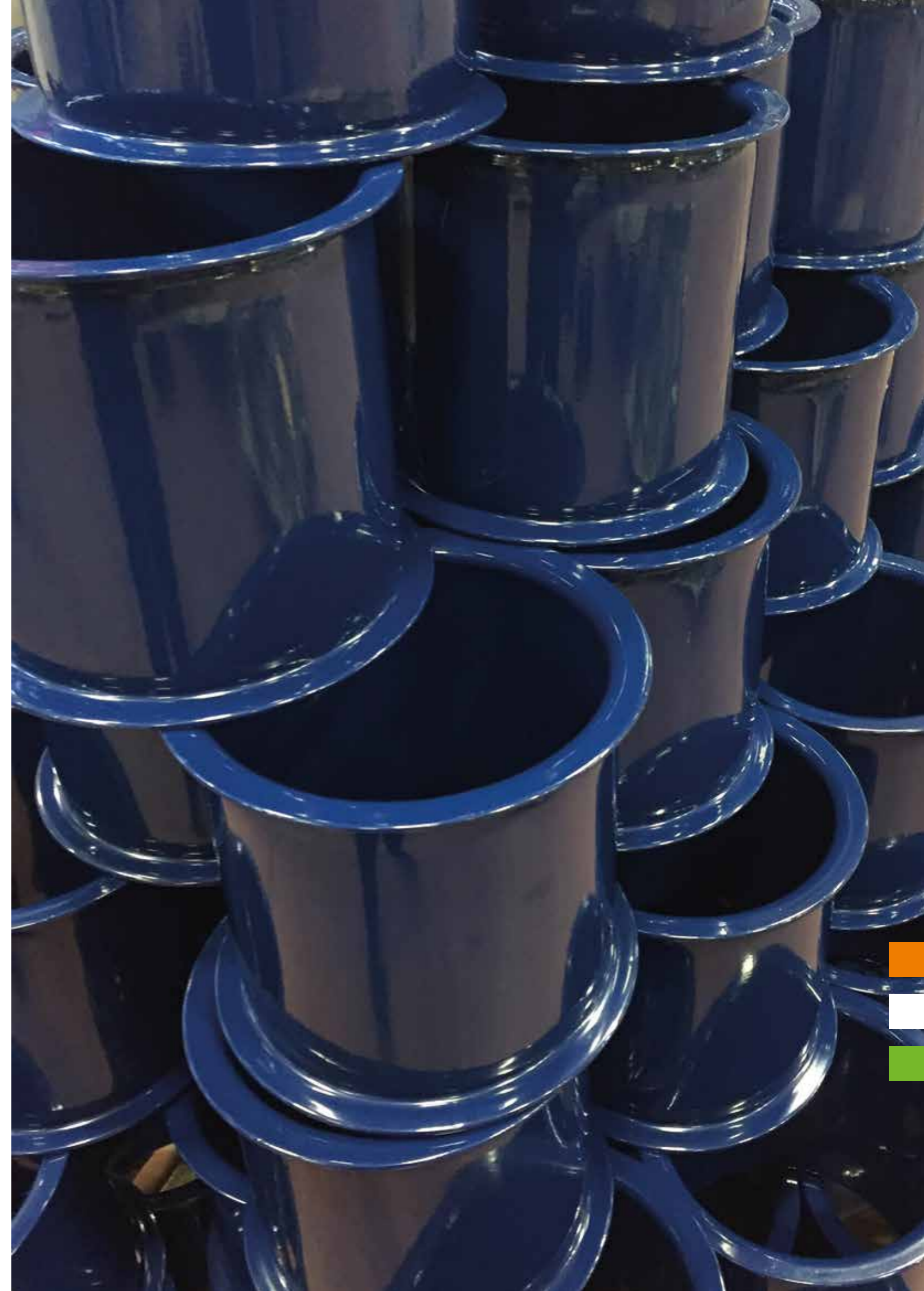



- AABO-IDEAL headquarters and subsidiaries
- AABO-IDEAL agents

Represented world wide



AABO IDEAL
GROUP

AABO-IDEAL A/S | Industrivej 7 | DK-5600 Faaborg
+45 6261 6125 | info@aabo-ideal.com | www.aabo-ideal.com