

## DRY FILTER BOOTH TFAS

The spray booth TFAS is designed for the spray painting or grinding of small parts that are easy to take in and out of the cabinet. It is composed from lacquered sheet metal sections and features a workbench consisting of a 600 mm deep grate, and a removable spill tray that makes cleaning simple.

Moreover, an induction cabinet is created by a CI Filter slanted between the back of the workbench and ceiling. An exhaust connection 315 mm in diameter is also provided.

LED light fixtures (ATEX classification 3G/zone 2) is mounted in the booth's ceiling. Our Turntable GFX 601 can be used to paint or enamel all sides of small parts when on the workbench's grate. The grate can also be replaced with our Rotary Worktable RAB100.



When the TFAS is used as a grinding booth, the grate is replaced with duckboard (wooden slats). The TFAS is delivered factory pre-assembled and painted in a white colour scheme with grey front plates.

### Exhaust ventilator

Exhaust ventilator is not included in the delivery. It has to be chosen from separate product specification and adapted to air flow and pressure drop at actual installation.

The given air flow in the table is adapted to EN 12215 for manual painting. Air speed in the booth opening shall be 0,5 m/s.

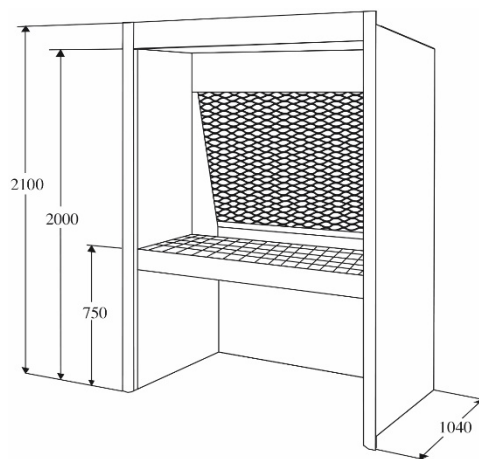

Type TFAS	Internal width [mm]	External width [mm]	Recommended air flow [m³/h]	Diameter exhaust air [mm]	Lighting [Lm]	Classified zone
100	1000	1200	0,6	315	1 pcs 2500lm	Zon 2
140	1400	1600	0,9	315	1 pcs 5000lm	Zon 2
200	2000	2200	1,3	315	1 pcs 7500lm	Zon 2